

APPLICATION:

PRODUCT:

DrainKing WASTE VALVE ROUGH CHROME

JOB NAME:

SPECIAL CONFIGURATION (CHECK BASE MODEL AND OPTIONS)

QUANTITY: ITEM NO.

MODEL:

- 28959W/ LOCKING BASKET STRAINER & 19" x 21" OVERFLOW
- 28975W/ LOCKING BASKET STRAINER & 14" x 16" OVERFLOW

OPTIONS OR MODIFICATIONS

OTHER _____

FEATURES:

- *DUAL TEFLON SEALS
- *STAINLESS STEEL BALL
- *CAST RED BRASS BODY, CHROME PLATED
- *EXTRA STURDY STAINLESS STEEL CLAMPING RING
- *"CLEAR THROUGH" OPENING - NO NEED TO DISASSEMBLE IF SNAKING IS REQUIRED
- *INDUSTRY STANDARD "SEALING" ANGLE - FITS FLUSH TO STANDARD STAINLESS STEEL SINKS
- *STAINLESS STEEL LOCKING BASKET STRAINER
- *1/4 TURN FULLY OPENS AND CLOSES VALVE

DRAIN RATE

*12 GPM

SHIPPING WEIGHT

*10.0 LBS

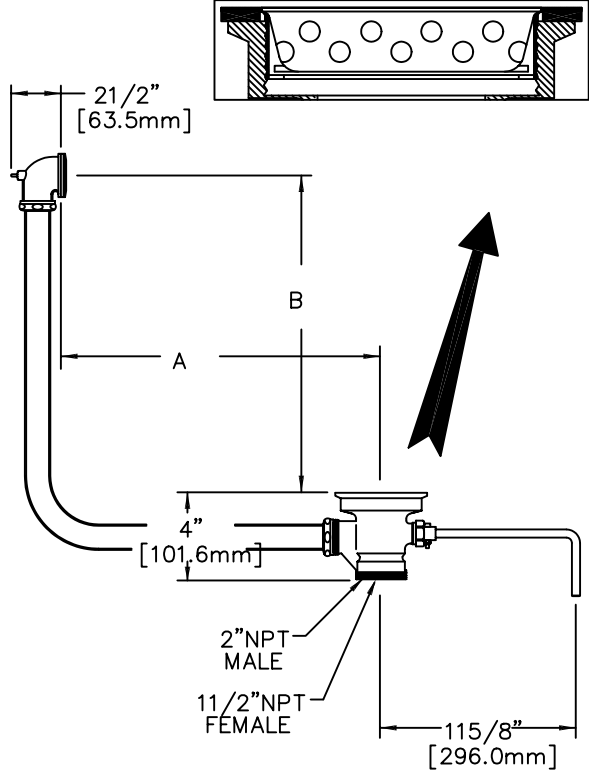

MODEL	19" X 21"
	DIM "A" DIM "B"
28959	19" [482.6mm] 19 1/4" [489.0mm]

MODEL	14" X 16"
	DIM "A" DIM "B"
28975	14" [355.6mm] 14 1/4" [362.0mm]

ROUGH-IN:

